



**STRONG PARTNERS.
TOUGH TRUCKS.™**



A25-30XNT SERIES BROCHURE/TECHNICAL GUIDE

BRIGGS®

EQUIPMENT MEXICO

info@BriggsEquipmentMexico.com

55-9020-5042

> A25-30XNT FEATURES & OPTIONS

The A25-30XNT series has been designed to maneuver in the tightest of spaces and to move pallets in containers and warehouses, delivering a cost effective solution to meet the requirements of applications where space is at a premium. This series offers many functions and features, including extended shift performance settings and a high mounted Multifunction Display, which are standard across the range of Hyster® electric forklift trucks.

DEPENDABILITY

- Strong chassis construction provides excellent durability and stability, ensuring the operator can maneuver and carry out handling operations with confidence, enhancing productivity.
- The use of proven components, such as O-ring face seal fittings and sealed electrical connectors, as well as a CANbus communications network ensure long term reliability.
- Hall-Effect sensors are virtually maintenance free, making the truck more reliable and decreasing downtime.
- AC motor technology allows the truck to work longer and more reliably, reducing downtime.
- The Auto Deceleration System automatically slows the truck when the operator's foot is removed from the accelerator, reducing brake usage and associated brake maintenance requirements.
- The unique Power-Assisted Braking System further increases brake and drivetrain life by automatically utilizing traction motor braking in proportion to operator brake pedal pressure, reducing the demand on the service brakes. The rugged drum-type brakes feature a strengthened "backing plate" for excellent durability.
- A steel hood and durable side covers provide increased resistance to impact damage and general wear and tear.

LOW COST OF OWNERSHIP

- A25-30XNT trucks provide tremendous flexibility to customize the truck's hydraulic and traction performance to your application. A trained Hyster technician can maximize your truck's performance, whether it requires extended battery shift life, aggressive performance or fast travel speeds for long hauls.
- The Pacesetter Vehicle System Manager (VSM) continuously monitors and controls all major truck functions for efficiency and proper operation.
- Durable, quality components mean long term reliability and lower maintenance costs. Virtually maintenance-free components, such as AC motors, allow for 500-hour service intervals.
- A thermal management system protects the motors and controllers, leading to reduced maintenance costs.
- Fast delivery of diagnostic information allows precise troubleshooting, easy maintenance planning and lower costs.

ERGONOMICS

- This truck has been intelligently designed, focusing on the operator. Generous foot space, an intuitive pedal arrangement and a low step height offer a comfortable working space for the operator. This means on/off access and driving in reverse cause less fatigue over long shifts.
- The operator compartment features a standard non-suspension vinyl seat. Full suspension seats are available, which help to provide optimum operator comfort and a smooth ride.
- A class leading low noise level of 59dB(A) reduces the stress on operators making them more productive by ensuring that they are comfortable for longer amounts of time.
- The optional adjustable mini-lever module armrest with built-in hydraulic controls, integrated directional control, power disconnect button and horn offers the ultimate in comfort and control.
- A display mounted in the upper right hand corner of the overhead guard keeps the operator's field of vision clear and provides at-a-glance information regarding truck operating conditions and performance.

PRODUCTIVITY

- 24-volt rear-wheel drive with AC motors throughout provides smooth acceleration and excellent travel, torque and lifting performance, delivering efficient and productive load handling.
- The A25-30XNT is the most compact truck Hyster offers in its class, with the tightest turning circle for excellent maneuverability in working aisles. This allows the operator to move faster with more confidence in restricted spaces or congested loading/unloading bays. An overall truck width of 39.2 inches facilitates block stacking in tight spaces.
- The VISTA™ mast offers generous visibility allowing the operator to work quicker when picking and depositing loads.
- With the Extended Shift feature turned off, the truck delivers a competitive top speed of 7.5 mph (rated load) and lifting speed of 59 ft/min (rated load).

SERVICEABILITY

- The steer column includes a diagnostic port which allows trained dealer technicians to connect the PC Service Tool for easy access to the truck's on-board diagnostics and programming.
- Easily removable rear cover provides no-hassle access to power contactor, fuses and relays.

SERVICEABILITY (CONTINUED)

- The truck is fully serviceable without having to remove the battery – the motor, pump, controller and oil tank are easily accessible.
- Downtime for service requirements is minimized, thanks to features such as maintenance-free AC motors, DIN wheel nuts, self-adjusting service brakes and gear-driven steering (no chain – no lubrication required), as well as extended service intervals.
- Standard service interval is 6 months / 500 hours, the drive axle / transmission oil change is 4000 hours, and the hydraulic oil change is 4000 hours. The standard warranty is 12 months / 2,000 hours and the powertrain warranty is 36 months / 6,000 hours .

OPTIONS

- Five different mast offerings: two 2-stage and three 3-stage
- Various length forks
- Integral Hook Type Sideshift
- Non-marking, pneumatic shaped solid tires
- Full suspension vinyl and cloth seats with and without swivel
- Telescopic steering column with tilt memory
- Dual rear view mirrors
- Single panoramic mirror
- Keyless Start
- Operator Password Start Interlock
- Operator daily checklist
- Monotrol® pedal
- LED light package
- Visible alarm
- Audible backup alarm
- DC to DC converters
- Load weight indicator
- Impact monitor
- System monitoring
- TouchPoint mini-levers
- Return to Set Tilt (RTST)
- Cooler / Freezer construction package



> A25-30XNT DIMENSIONS

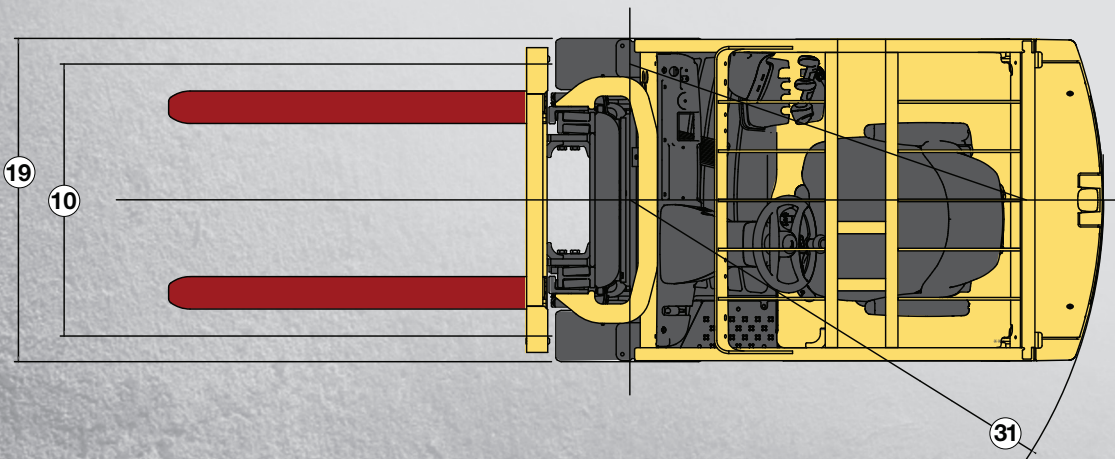
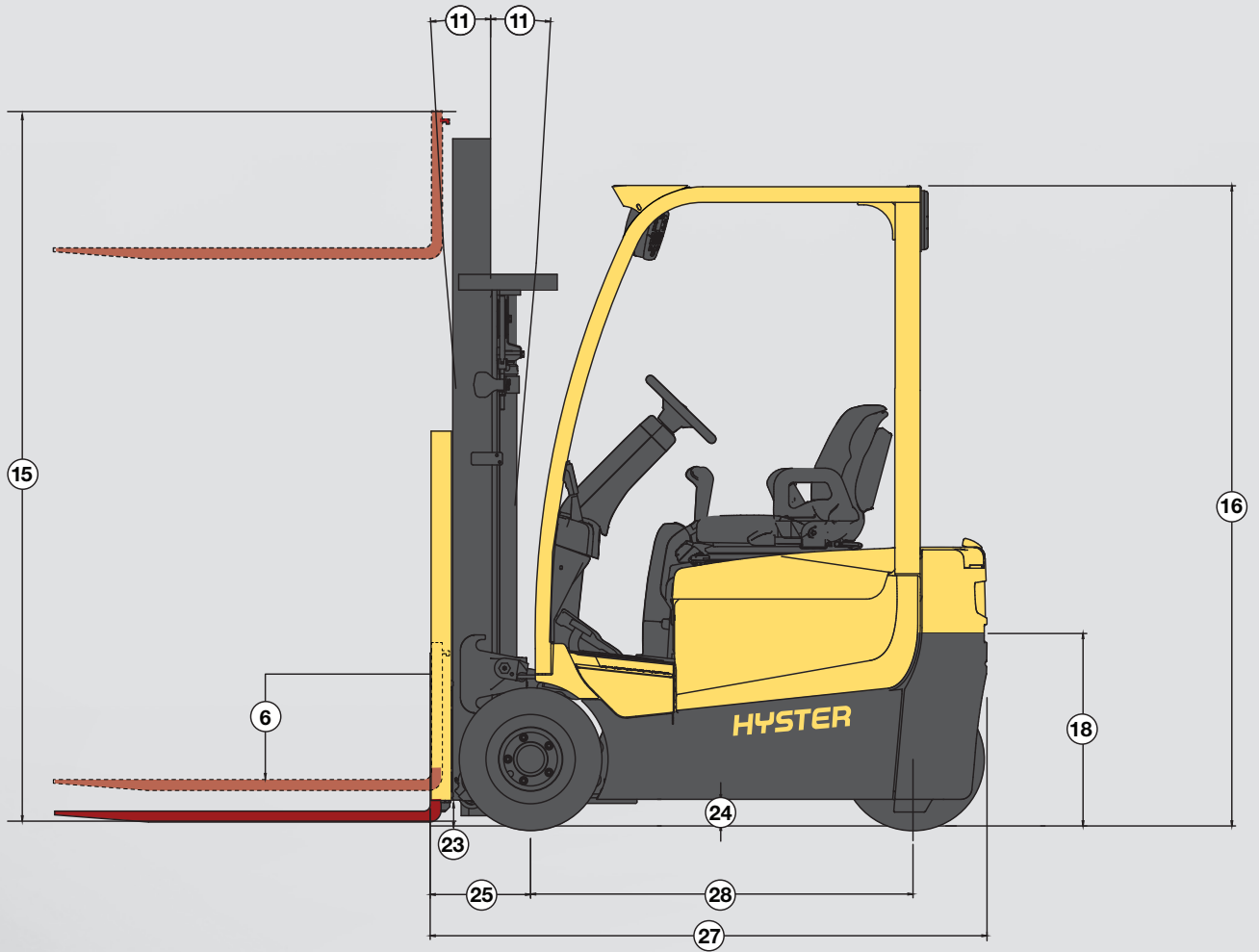

Circled dimensions correspond to the line numbers on the tabulated chart inside the Technical Guide. Dimensions are in inches (millimeters).

A25-30XNT DIMENSIONS <

GENERAL				Hyster	Hyster
1	Manufacturer			A25XNT	A30XNT
2	Model Designation			Electric	
3	Power			Sit	
4	Operation			2500 (1134) 3000 (1361)	
5	Rated Capacity	lb (kg)		24 (610)	
6	Load Center	in (mm)		Pneumatic Shaped Solid / Pneumatic Shaped Solid	
TIRES & WHEELS					
7	Tire Type - Cushion, Solid, Pneumatic, etc.	Front / Rear		18 x 7-8 / 18 x 7-8	
8	Tire Size	Front / Rear		2 / 1X	
9	Wheels - Number	X=Driven	Front / Rear		
10	Tread	φ Tires	Std / Wide	in (mm) 32.9 / 35.3 (836 / 896)	
11	Mast Tilt	Std		degrees 5F / 5B	
12	Mast - Lowered Height	Std Mast		in (mm) 78 (1980)	
13	Free Lift - Top of Fork	Std 2 Stg LFL Mast		in (mm) 5 (140)	
14		Opt 3 Stg FFL Mast with / without LBR		in (mm) 33 / 61 (849 / 1572)	
15	Lift Height - Top of Fork	Std 2 Stg LFL Mast		in (mm) 112 (2860)	
16	Mast - Extended Height	Std Mast with / without LBR		in (mm) 161 / 133 (4089 / 3368)	
17	Overhead Guard Height	Std / Opt		in (mm) 81.1 / 77.9 (2060 / 1980)	
18	SIP to Bottom Std OHG	Nominal	Std / Susp / Swivel	in (mm) 39.8 / 38.6 / 38.7 (1011 / 982 / 984)	
19	Tow Pin Height	Vertical Center of Pin		in (mm) 24.2 (615)	
20	Overall Width	Std / Wide Tread		in (mm) 39.2 / 41.6 (996 / 1056)	
21	Forks	Thickness x Width x Length		in (mm) 1.6 x 3.1 x 43.3 (40 x 80 x 1100)	
22	Standard Carriage Width	Class II		in (mm) 35.7 (907)	
23	Ground Clearance	Lowest Point	NL / RL	in (mm) 3.3 / 2.9 (86/74)	
24	Ground Clearance	Center of Truck	NL / RL	in (mm) 3.5 / 3.3 (88 / 85)	
25	Load Distance	Center of Wheel to Face of Forks		in (mm) 12.8 (326)	
26	Battery Compartment	Height		in (mm) 25 (635)	
27		Width		in (mm) 32.9 (835)	
28		Length		in (mm) 17.3 (439) 19.4 (493)	
29	Length to Face of Forks	Chassis Length		in (mm) 67.9 (1724) 70.0 (1778)	
30	Wheelbase			in (mm) 46.0 (1168) 48.1 (1222)	
31	Right Angle Stack (See Note 2)			in (mm) 119.1 (3025) 121.2 (3079)	
32	Equal Aisle	90° Intersecting Aisle		in (mm) 66.3 (1683) 66.9 (1700)	
33	Outside Turning Radius			in (mm) 55.0 (1398) 57.2 (1452)	
WEIGHT					
34	Truck Weight	Without Battery	NL	lb (kg) 4560 (2068) 4830 (2191)	
35	Axle Loading - Front	Static with Max. Wt. Battery	NL / RL	lb (kg) 2702 / 7206 (1226 / 3269) 2783 / 8083 (1262 / 3666)	
36	Axle Loading - Steer	Static with Max. Wt. Battery	NL / RL	lb (kg) 3394 / 1389 (1539 / 630) 3663 / 1363 (1662 / 618)	
37	Voltage			VOLTS 24	
PERFORMANCE					
38	Travel Speed	Extended Shift OFF	NL / RL	mph (km/h) 7.8 / 7.5 (12.5 / 12.0)	
39		Extended Shift ON	NL / RL	mph (km/h) 7.2 / 6.3 (11.6 / 10.1)	
40	Lift Speed	Std 2-Stg LFL Mast	NL / RL	ft/min (m/sec) 101 / 59 (.51 / .30)	
41		Opt 3-Stg FFL Mast	NL / RL	ft/min (m/sec) 94 / 45 (.48 / .23)	
42	Lower Speed	Std 2-Stg LFL Mast	NL / RL	ft/min (m/sec) 91 / 98 (.46 / .50)	
43		Opt 3-Stg FFL Mast	NL / RL	ft/min (m/sec) 85 / 98 (.43 / .50)	
44	Gradeability	5 Minute Rating	NL / RL	% 24.3 / 16.3 22.4 / 14.5	
45		60 Minute Rating	NL / RL	% 4.0/3.2 3.4/2.9	
46	Drawbar Pull	5 Minute Rating	NL / RL	lbf (N) 1399 / 1445 (6221 / 6426) 1403 / 1397 (6242 / 6212)	
47		60 Minute Rating	NL / RL	lbf (N) 219 / 214 (975 / 951) 218 / 212 (970 / 942)	
48	Brake	Method of Control	Service / Parking	Hydraulic / Mechanical	
49		Method of Operation	Service / Parking	Foot / Lever	
ELECTRIC					
50	Battery Type			Lead Acid	
51	Traction Motors	60 Minute Rating		hp (kW) 6.3 (4.7)	
52	Pump Motor	15 Minute rating		hp (kW) 8.0 (6.0)	
53	Traction Motor	Type / Control Method		AC / Transistor	
54	Pump Motor	Type / Control Method		AC / Transistor	
55	Number of Speeds	Traction / Pump		Infinitely Variable	
OTHER					
56	Step Height			in (mm) 19.1 (485)	
57	Floor Height	Lowest Point		in (mm) 20.6 (522)	
58	Attachment Relief Pressure			psi (bar) 2248 (155)	
59	Auxiliary Oil Flow			gal/min (l/min) 5.3 (20)	
60	Sound Level	Measured per ANSI B56.11.5		dB (A) 59	

Above specifications, unless otherwise listed, are for a standard truck without optional equipment. Right Angle Stack and Equal Intersecting Aisle dimensions provided with a 48" long and 40" wide pallet load, allowing zero clearance.

CERTIFICATION: Hyster lift trucks meet the design and construction requirements of B56.1-1969, per OSHA Section 1910.178(a)(2), and also comply with the B56.1 revision in effect at time of manufacture. Certification of compliance with the applicable ANSI standards appears on the lift truck.

NOTE 1: Performance specifications / ratings are for truck equipped as described under Standard Equipment in this Technical Guide. Performance specifications are affected by the condition of the vehicle and how it is equipped, as well as by the nature and condition of the operating area. Specifications are subject to change and the proposed application should be discussed with your authorized Hyster Company Dealer.

NOTE 2: The Industrial Truck Association (ITA) defines the formula for calculating Right Angle Stack on 3-wheel trucks with counter rotating load wheels as: $Right\ Angle\ Stack = OTR + \sqrt{(Load\ Distance + Load\ Length)^2 + (\frac{Load\ Width}{2})^2}$ (For a 40" wide by 48" long pallet load.) Hyster uses the above ITA formula to calculate Right Angle Stack on our 3 and 4 wheel trucks with a zero turn steer axle and counter rotating load wheels.

Some documentation incorrectly calculates Right Angle Stack on a 3-wheel zero-turn truck with counter rotating load wheels using the following formula: $Right\ Angle\ Stack = OTR + Load\ Distance + Load\ Length$. This formula generates a value which is invalid and lower than actual Right Angle Stack. When making comparisons, be sure the correct ITA formula is used to calculate Right Angle Stack.

> BATTERY AND MAST DIMENSIONS

BATTERY & COMPARTMENT SPECIFICATIONS												
Truck Model	Compartment Dim			Battery Dim - Max			Volts	No. of Cells	Max Capacity 6 Hour Rate	Weight		
	Width	Length	Height	"X"	"Y"	"Z"				Min	Max	
	in (mm)								amp hr (kwh)	lb (kg)		
A25XNT 17" Compartment	32.9 (835)	17.3 (439)	25 (635)	32.7 (830)	17.1 (435)	24.7 (627)	24	12	600 (14.4)	1256 (570)	1543 (699)	
A30XNT 19" Compartment	32.9 (835)	19.4 (493)	25 (635)	32.7 (830)	19.3 (489)	24.7 (627)	24	12	1000 (24)	1415 (642)	1620 (734)	

Battery Type: "EO" (Without Cover)

Battery Compartment Length is measured front to rear. Battery Compartment Width is measured across the truck

Battery Notes - Conventional Charging

Battery Connector: 24 volt - Red SBE®320 (Anderson Power Products® P/N E6342G1 or equivalent)

Battery Lead: Length 20" (508 mm), Position "A", 2/0 AWG

Handle (not required): SBE®320 (Anderson Power Products® : "A" TYPE (Grey) P/N 995G2 or equivalent)

MAST DIMENSIONS					
Maximum Fork Height (TOF)	Overall Lowered Height	Overall Extended Height		Free Lift (TOF)	
		with Load Backrest	w/o Load Backrest	with Load Backrest	w/o Load Backrest
in (mm)	in (mm)	in (mm)	in (mm)	in (mm)	in (mm)
2-STAGE LIMITED FREE LIFT (LFL)					
112 (2860)	78 (1980)	161 (4089)	133 (3368)	5 (140)	5 (140)
132 (3360)	88 (2230)	181 (4589)	153 (3868)	5 (140)	5 (140)
3-STAGE FULL FREE LIFT (FFL)					
169 (4300)	78 (1980)	218 (5531)	190 (4808)	29 (749)	57 (1472)
181 (4600)	82 (2080)	230 (5831)	202 (5108)	33 (849)	61 (1572)
192 (4900)	86 (2180)	242 (6131)	213 (5408)	37 (949)	65 (1672)

> COMPARISON: A-XNT VS. J-XNT

DIMENSIONAL DIFFERENCES					
Model Designation			A25XNT	A30XNT	J30XNT
Rated Capacity @ 24" LC		lb (kg)	2500 (1134)	3000 (1361)	3000 (1361)
Overhead Guard Height	Std	In (mm)	81.1 (2060)	81.1 (2060)	81.5 (2070)
Overall Width	Std	In (mm)	39.2 (996)	39.2 (996)	41.3 (1050)
Ground Clearance, Center of Truck	NL / RL	In (mm)	3.5 / 3.3 (88 / 85)	3.5 / 3.3 (88 / 85)	3.7 / 3.5 (95 / 90)
Length to Face of Forks		In (mm)	67.9 (1724)	70 (1778)	71.2 (1808)
Wheelbase		In (mm)	46 (1168)	48.1 (1222)	50.8 (1290)
Right Angle Stack		In (mm)	119.1 (3025)	121.2 (3079)	122.2 (3103)
Equal Aisle		In (mm)	65.9 (1675)	66.9 (1700)	69.3 (1759)
Outside Turning Radius		In (mm)	55 (1398)	57.2 (1452)	58.3 (1481)

KEY PERFORMANCE DIFFERENCES					
Model Designation			A25XNT	A30XNT	J30XNT
Rated Capacity @ 24" LC		lb (kg)	2500 (1134)	3000 (1361)	3000 (1361)
Volts			24	24	36
Travel Speed Extended Shift OFF	NL / RL	mph (km/h)	7.8 / 7.5 (12.5 / 12.0)	7.8 / 7.5 (12.5 / 12.0)	9.8 / 9.8 (15.7 / 15.7)
Travel Speed Extended Shift ON	NL / RL	mph (km/h)	7.2 / 6.3 (11.6 / 10.1)	7.2 / 6.3 (11.6 / 10.1)	8.7 / 8.7 (14 / 14)
Lift Speed Std 2-Stg LFL Mast	NL / RL	ft/min (m/sec)	101 / 59 (.51 / .30)	101 / 59 (.51 / .30)	128 / 77 (.65 / .39)
Lower Speed Std 2-Stg LFL Mast	NL / RL	ft/min (m/sec)	91 / 98 (.46 / .50)	91 / 98 (.46 / .50)	93 / 100 (.47 / .51)
Gradeability 5 Minute Rating	NL / RL	%	24.3 / 16.3	22.4 / 14.5	38.4 / 26.5
Gradeability 60 Minute Rating	NL / RL	%	4 / 3.2	3.4 / 2.9	6 / 4.4
Drawbar Pull 5 Minute Rating	NL / RL	lbf (N)	1399 / 1445 (6221 / 6426)	1403 / 1397 (6242 / 6212)	2719 / 2714 (12096 / 12072)
Drawbar Pull 60 Minute Rating	NL / RL	lbf (N)	219 / 214 (975 / 951)	218 / 212 (970 / 942)	458 / 462 (2038 / 2054)

Green highlight indicates advantage.

INNOVATIVE TRUCKS ENGINEERED TO MEET THE MOST DEMANDING APPLICATIONS

For nearly 90 years, Hyster has conquered the world's most demanding applications. In the 1920s Hyster started as a manufacturer of lifting machines used in the rigorous logging industry of the United States' Pacific Northwest. A few years later the first forklift trucks were invented and the Hyster brand quickly gained its reputation for rugged quality. Hyster® lift trucks are designed to lower your cost of operations. Every truck we make — gasoline, LPG, diesel and electric — is purpose-built to excel in its application. Every truck is also backed by an unmatched network of specialists.



Dealer Network — Our Dealer Network can offer the expertise of fleet managers, parts suppliers, capital procurement specialists and trainers. Carefully chosen dealers fully understand customer applications, assist in selecting the right lift truck and provide fast, reliable support.



Hyster Fleet Services — Even if you operate other brands, we can manage your maintenance and replacement plan. We can offer complete fleet analysis, fleet history summary and a cost-effective proposal for replacement and scheduled maintenance.



Parts — With genuine Hyster® replacement parts and UNISOURCE™ parts for all makes of lift trucks, we are your one-stop source for lift truck parts. In fact, we offer more than 7 million part number crosses for most brands of materials handling and other in-plant mobile equipment.



Rental Products — When leasing or buying isn't a practical option, we have access to more than 14,000 units for short- and long-term rental. We'll help you maintain output in a cost-effective manner.



Hyster Capital — We can arrange solutions for special financing requirements, taking the difficulties out of buying the equipment you need. Whether you purchase or lease a new or used lift truck, Hyster Capital offers superior service and competitive rates.



Special Products Engineering Department (SPED) — Different materials require different handling. That's why we can work with you to customize your lift trucks. From strobe lights to specially made forks, SPED has the tools to help you get the job done right.



Operator Training — Proper education in operating lift trucks minimizes the risk of injuries due to accidents while increasing productivity. Hyster offers OSHA-compliant materials that support the training of qualified operators.



Service — Your local Hyster® dealer offers a flexible, customized and comprehensive maintenance plan based on each lift truck's operation environment. Hyster service programs offer scheduled inspections and maintenance, along with quick, responsive service dispatched to your location.



Hyster, , and STRONG PARTNERS. TOUGH TRUCKS. and MONOTROL are registered trademarks in the United States and certain other jurisdictions. Hyster products are subject to change without notice.

Trucks may be shown with optional equipment. © 2020 Hyster Company. All rights reserved.

BRIGGS
EQUIPMENT MEXICO
info@BriggsEquipmentMexico.com
55-9020-5042